

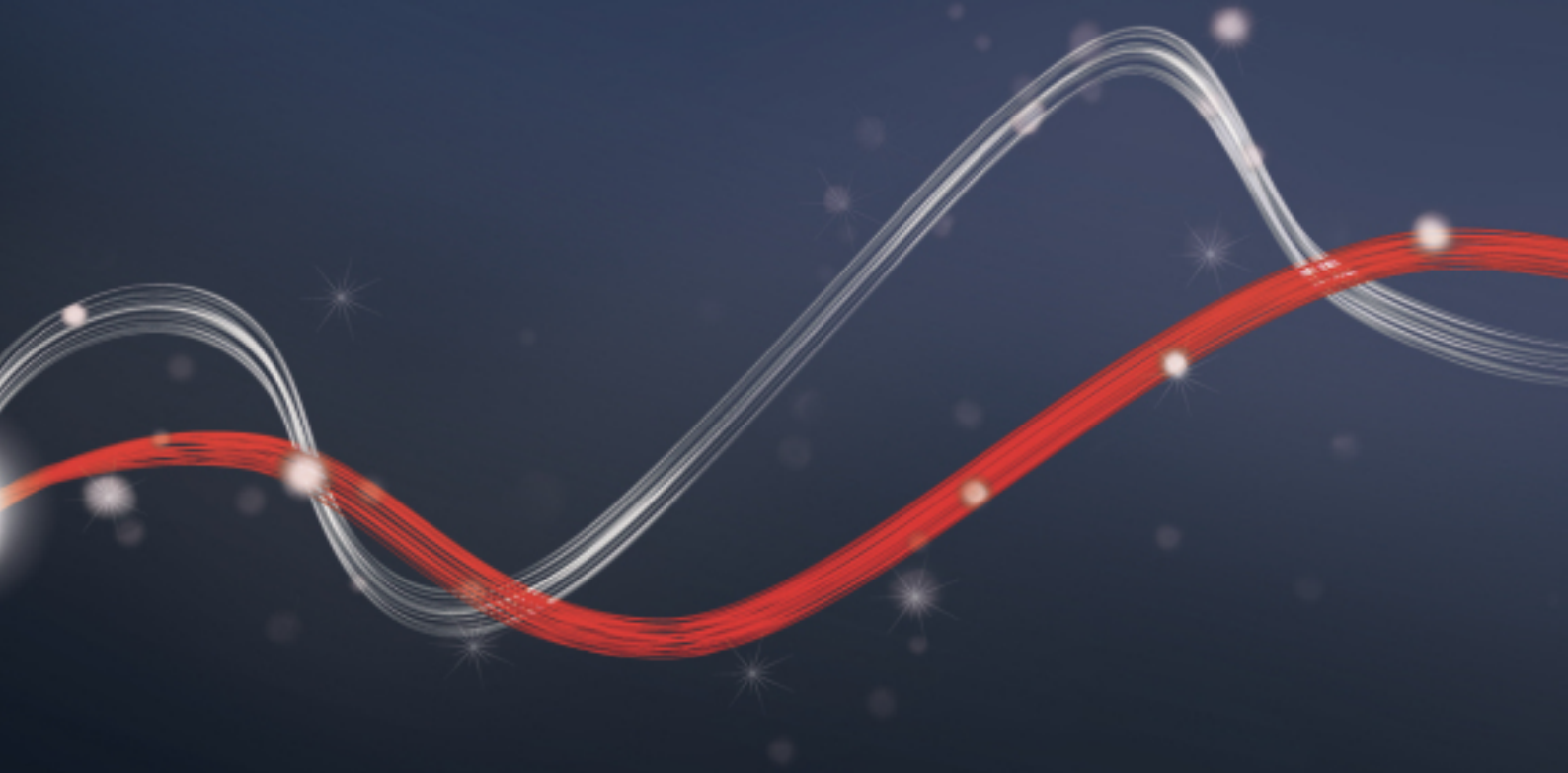

Be ahead



P7 / P4,5



Product

PLUS

CONTROL UNIT
TECHNICAL FEATURES

ACCESSORIES

DISCOVER U-LINK

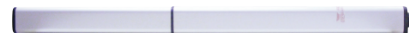

Extremely sturdy and reliable hydraulic operators for industrial and condominium use. They can automate swing gate leaves up to 7m wide and weighing up to 500kg.

Smooth, silent gate movements are guaranteed by the extremely high-performance hydraulic system and the closing slowdown.

Maximum precision in traction and thrust force control is guaranteed by the by-pass valve system.

P7 / P4,5

Code	Name	Description
P935061 00001	P4,5	Reversible hydraulic operator for swing gates up to 4.5 m. 500 kg in weight. Cycle time 28+slowdown sec. Useful travel 390 mm. max angle 123 °.
P935061 00004	P4,5 WINTER	Reversible hydraulic operator for swing gates up to 4.5 m. 500 kg in weight. Cycle time 28+slowdown sec. Useful travel 390 mm. max angle 123 °.
P935060 00001	P7	Reversible hydraulic operator for swing gates up to 7 m. 500 kg in weight. Cycle time 42+slowdown sec. Useful travel 390 mm. max angle 123 °.
P935060 00004	P7 WINTER	Reversible hydraulic operator for swing gates up to 7 m. 500 kg in weight. Cycle time 42+slowdown sec. Useful travel 390 mm. max angle 123 °.

· Product

· **PLUS**

· CONTROL UNIT
· TECHNICAL FEATURES

· ACCESSORIES

· **DISCOVER U-LINK**

PLUS



The rear articulated brackets and jointed rod make installation simple and reliable in all situations.



The brass release knob, protected with a personal key, facilitates the manual opening of the gate in the event of a power cut.



The closing slowdown guarantees silent, smooth movements on even the biggest gates. Also, the adjustment screw makes it possible to adapt the slowdown intensity to needs of each situation.

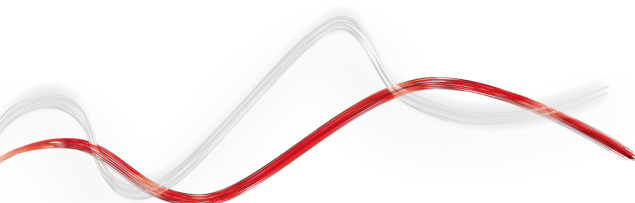

Product

PLUS

CONTROL UNIT
TECHNICAL FEATURES

ACCESSORIES

DISCOVER U-LINK

RIGEL 5 D113693 00003 Recommended

Universal control panel with display for one or two 230V - 600+600W operators



- Application: universal control panel for one or two operators
- Board power supply: 230V single-phase
- Operators power supply: 230V single-phase 600+600W
- Main features: removable terminal blocks, programming and diagnostics with display, incorporated dual channel receiver, plug-in connector for additional receiver, electric snap latch or magnetic lock connection, electronic torque limiter, electronic slowdown during opening and closing, separate limit switch inputs for each motor, possibility of traffic-light management and hydraulic operator pre-heating with 55R5 board
- Main functions: automatic re-closing, separate motor working times, stays locked when closed, water hammer, 2/3/4 step logic, partial opening, fast closing, separate opening and closing
- Compatibility: RIGEL 4

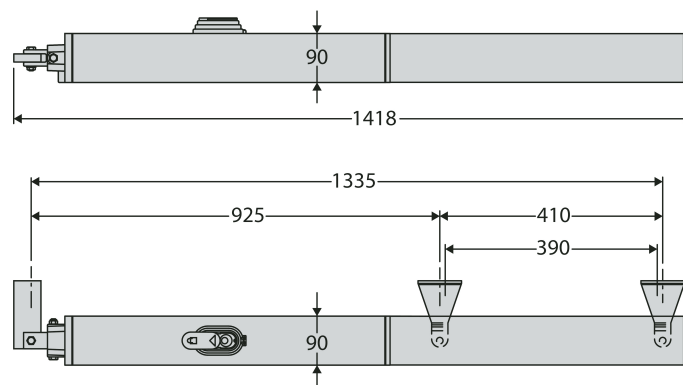

	P4,5	P4,5 WINTER	P7	P7 WINTER
Control unit	ALCOR N, RIGEL5			
Motor power supply	230 V			
Power input	250 W			
Maximum angle	123 °			
Slowdown	during closing			
Impact reaction	hydraulic clutch			
Locking	solenoid lock			
Frequency of use	very intensive			
Release	reversible			
Environmental conditions	from -10 °C to 60 °C	from -30 °C to 60 °C	from -10 °C to 60 °C	from -30 °C to 60 °C
Protection rating	IP55			











· Product

· PLUS

· CONTROL UNIT
· TECHNICAL FEATURES

· **ACCESSORIES**

· DISCOVER U-LINK

	Code	Name	Description
	D113693 00003	RIGEL 5	Universal control panel with display for one or two 230V - 600+600W operators
	D113706 00002	ALCOR N	Control panel with dip switches and potentiometers for one or two 230V/300W operators for swing gates
	D113680 00002	ALPHA SD	Universal control panel with potentiometers for one 230V/500W single-phase operator
	N190104	BIR C	Rubber safety edge (H 30 mm), price per m
	D113748 00002	RADIUS B LTA 230 R1	Flashing light with incorporated antenna for motors with power supply 230 V.
	D113749 00002	RADIUS B LTA 230 R2	Flashing light without incorporated antenna for motors with power supply 230 V.
	D111013	ME	Control board for 12Vac solenoid lock for 230V automation systems Control board for 12Vac solenoid lock for 230V automation systems
	D831081	CMS	Sign
	P111401 00001	VENTIMIGLIA NS	Infrared device for BIR C or BAR C safety edges (conforms to EN 12978 Standard)
	N999131	NAT	Adapter for 230V hydraulic operators for inserting the spiral cable protection sheath
	P123026	B 00 R01	Metal guard for B LTA
	P123025	B 00 R02	Wall mounting for B LTA series flashing beacons

Product

PLUS

CONTROL UNIT
TECHNICAL FEATURES

ACCESSORIES

DISCOVER U-LINK

	Code	Name		Description
	P111528	THEA A15 O.PF		Pair of adjustable photocells with integrated flashing light. Possibility of directing the beam 40 ° horizontally and 10 ° vertically. IR signal synchronised to prevent any risk of blinding. Range 30 m. Power supply 24 V ac/dc. For external application.
	P111714	THEA A15 O.PF UNI		Pair of universal photocells suitable for non-Bft automation devices, adjustable with integrated flashing light. Possibility of orienting the beam 40 ° horizontally and 10 ° vertically. Synchronised infrared signal to prevent any possibility of blinding. Range 30 m. Power supply 24 V ac/dc. Pair of universal photocells suitable for non-BFT automation systems, adjustable with integrated flashing light. Beam can be oriented 40° horizontally and 10° vertically. Synchronised infrared signal to avoid any possibility of accidental dazzling. Range 30 m. Power supply 24 V ac/dc. For external application.
	D111904	MITTO B RCB02 R1		Transmitter with 2 channels. Range 50/100 m. Power supply 12 V with 1 battery type 23 A
	P121024	Q.BO TOUCH		Wireless digital touchpad with 433MHz rolling code operation. Manages up to 10 channels and 100 codes.
	P121022	Q.BO KEY WM		Key selector for outdoor use with double contact. Key selector for outdoor use with double contact.
	P121023	Q.BO KEY WM AV		Vandalproof key selector with double contact, for outdoor use. Metal structure. Vandalproof key selector with metal structure. Vandalproof key selector with double contact, for outdoor use. Metal structure.
	P111052	CM1700		Mechanical safety edge, length 1.7 m
	P111053	CM2000		Mechanical safety edge, length 2 m
	P111526	DESME A15		Pair of self-aligning photocells. Range 30 m. Power supply 24 V ac/dc. Pair of self-aligning photocells. Range 30 m. Power supply 24 V ac/dc.
	P903018	PHP		Pair of aluminium posts for THEA/DESME series photocells Height 522 mm
	D121016	ECB DX		Right-hand horizontal solenoid lock, 12-24V
	D121017	ECB SX		Left-hand horizontal solenoid lock, 12-24V
	D121018	ECB VERTICALE		Vertical solenoid lock, 12-24V



· Product

· PLUS

· CONTROL UNIT
· TECHNICAL FEATURES

· **ACCESSORIES**

· DISCOVER U-LINK

	Code	Name	Description
	P123001 00001	EBP	EBP 230Vac electric drop lock
	P123006 00001	EBPE 52	230Vac solenoid lock with zero stop resistance, also with release from outside for gates of max thickness 50 mm
	P123008 00001	EBPE 75	230Vac solenoid lock with zero stop resistance, also with release from outside for gates of max thickness 75 mm
	P123001 00013	EBP 24	24Vac solenoid lock, with 230/24V transformer installable in control panel

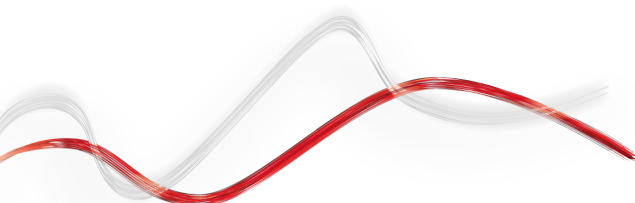

· Product

· PLUS

· CONTROL UNIT
· TECHNICAL FEATURES

· ACCESSORIES

· DISCOVER U-LINK

What is U-Link?

The innovative technology that gives you new power

An exclusive Bft innovation: U-Link (Universal Link) is an exclusive Bft platform that allows the creation of technological ecosystems. In Home Automation Access, it allows communication with all the home access automation devices of any brand. So you save time and can control everything with ease, without any worries.

It is intuitive

Easy to install and use

It is scalable

Allows an unlimited number of devices to be added

It is flexible

Allows the creation of groups of interconnected products

It is practical

Works with or without a web connection

It is functional

Parameters can be controlled remotely via dedicated applications

· Product

· PLUS

· CONTROL UNIT
· TECHNICAL FEATURES

· ACCESSORIES

· DISCOVER U-LINK

All in one scheme: discover this amazing technology

A unique platform **allowing the creation of technological ecosystems** offering a wide range of solutions for different sectors.

Thanks to the B-Eba cards and the Clonix U-Link receiver, this proprietary platform featured by Bft products adapts to any protocol and access automation product (even BFT, non-native U-Link or non-BFT products), and is used in various sectors. Each device thus becomes smart and can be interconnected with other systems, thanks to a language that becomes universal.

U-Base 2



Software to install and easily and comfortably carry out maintenance and identify any malfunction of U-link compatible operators.

U-SDK



U-SDK is the innovative application that can make Bft automation systems compatible and easily integrated with a BMS network for the supervision of buildings.



Magistro

An innovative and easy to install system for easily managing all home automation systems.



U-Control

U-Control is the application that helps the quick and easy integration of BFT automation systems in large building management systems.



Blue-Entry

Technology abreast of the times and attentive to daily needs: thanks to the use of U-link the house gate can now be opened with just your smartphone.



Clonix U-Link

Allows the connection of non-native U-Link products or non-Bft products to U-Link systems.

Bft operators, non-native U-Link products or a product belonging to other brands: can they be connected to U-Link? Yes, thanks to the Clonix receivers. Accessories that know no limits.



B-eba

A direct line with your operators.

B-eba expansion cards allow the connection of external devices, such as PCs, smartphones and tablets, to a Bft operator or Clonix receiver, or the connection of several Bft products in a U-Link network. These accessories integrate with U-Link technology and Bluetooth, Z-Wave, TCP/IP protocols, as well as the RS485 serial connection.

A device that fully translates what Bft means for interconnectivity.

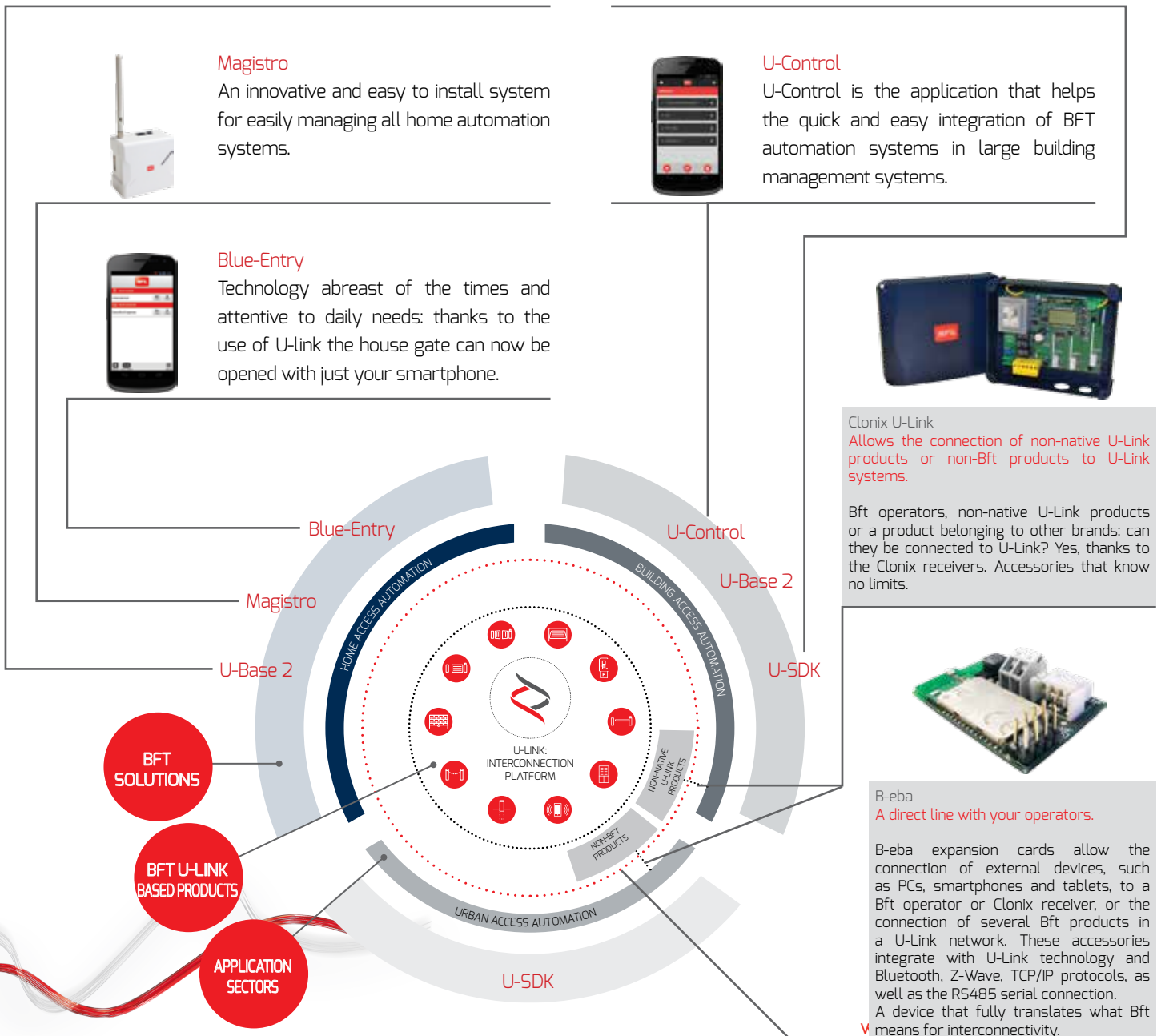



INFORMATION REGARDING THE PROTECTION OF THE INDUSTRIAL AND INTELLECTUAL PROPERTY RIGHTS OF BFT. BFT S.p.A. protects its industrial property by depositing trademarks, patents, models and designs. The intellectual property of BFT S.p.A. is protected by copyright law. BFT S.p.A. also protects its know-how by taking measures to protect the technical and commercial information inherent in its company and products. All the products in this catalogue are ORIGINAL BFT MODELS and only BFT S.p.A is authorised to produce them and market them anywhere in the world. All the commercial names in this catalogue are owned by BFT S.p.A., and only BFT S.p.A. is authorised to use them in relation to the corresponding merchandise category. FALSIFIERS WILL BE PROCEEDED AGAINST IN ACCORDANCE WITH BOTH CIVIL AND CRIMINAL LAW. THESE CONDITIONS NOT ONLY GUARANTEE THE INTELLECTUAL PROPERTY RIGHTS OF BFT, BUT ALSO PROTECT CUSTOMERS BY GUARANTEEING THAT THE PRODUCTS THEY ARE PURCHASING ARE ORIGINAL BFT PRODUCTS RESULTING FROM STUDIES AND DESIGNS WITHIN THE BFT COMPANY.