

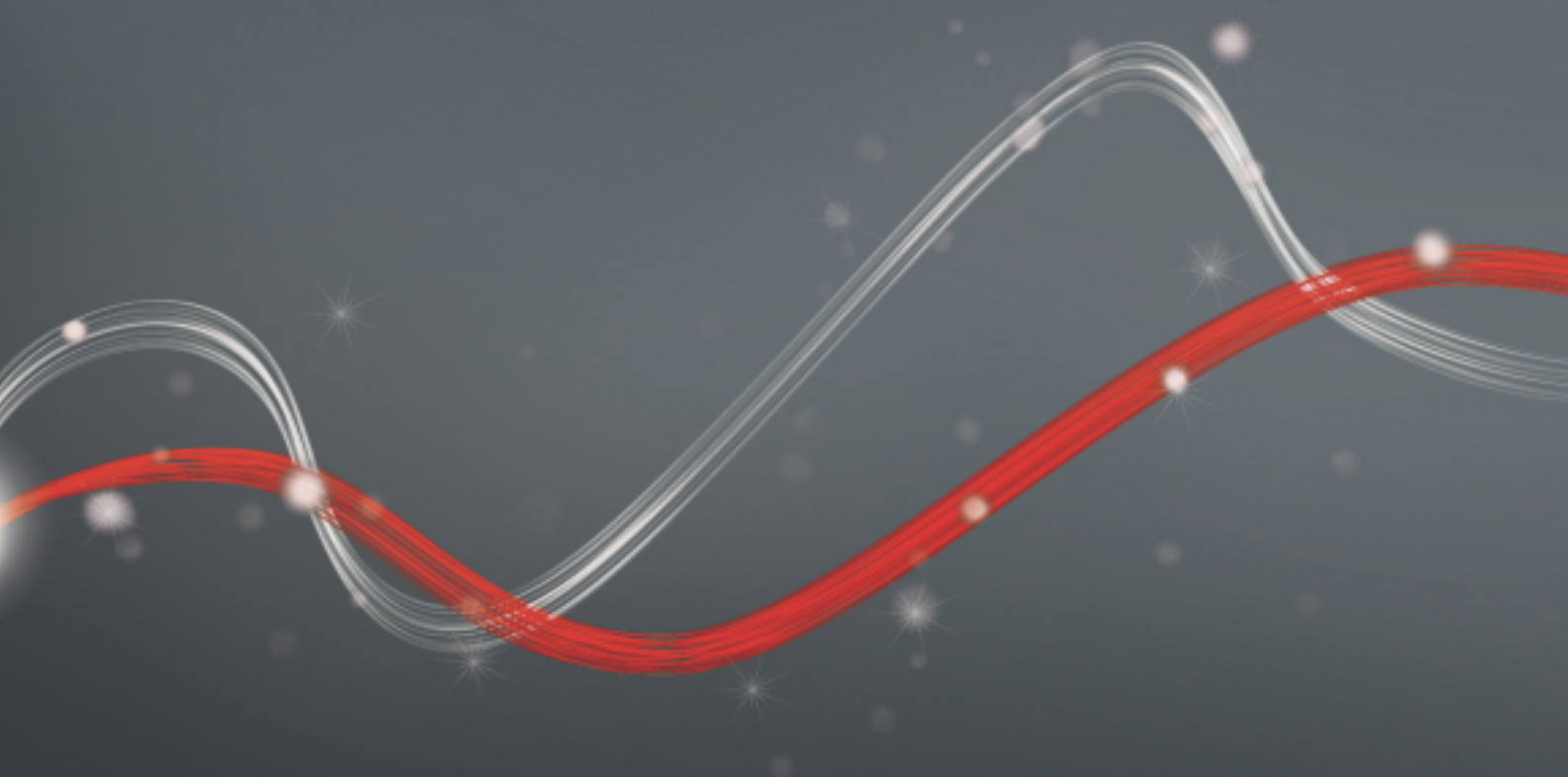

Be ahead



# ARES ULTRA BT A



## Product

• ADVANTAGES  
• PLUS

• CONTROL UNIT  
• TECHNICAL FEATURES

• ACCESSORIES

• DISCOVER U-LINK



- ee link
- 24 V
- er ready
- d-track
- U-Link



24 V sliding gates operator for intensive use, up to 1500 Kg in weight. Leaf speed up to 9 m/min. Magnetic limit switch and control board with U-link protocol embedded

**ARES ULTRA BT A**

Code	Name	Description
P926193 00002	ARES ULTRA BT A1000	Operator 24 V for sliding gates up to 1000 kg in weight. Leaf speed 9 m/min. U-Link and magnetic limit switch
P926191 00002	ARES ULTRA BT A1500	Operator 24 V for sliding gates up to 1500 kg in weight. Leaf speed 9 m/min. U-Link and magnetic limit switch
R925295 00001	ARES ULTRA BT KIT A1000 FRA	Complete 24V kit for sliding gates for leaves up to 1000 kg.

- U-Link
- U-Link
- U-Link

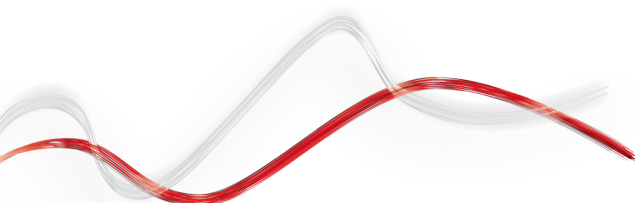

· Product

· **ADVANTAGES**  
· **PLUS**

· CONTROL UNIT  
· TECHNICAL FEATURES

· ACCESSORIES

· **DISCOVER U-LINK**

## ADVANTAGES

**Simplified and intuitive wiring:** the new Merak control units have standardised terminal blocks with different colours depending on the input and output function blocks for maximum ease of connection of operators and accessories.

**Obstacle recognition:** the D-Track torque management and control system ensures maximum safety for people and property, as well as facilitating certification of the system.

**Interconnectivity:** the Merak control unit is native to U-link protocol for control of the operator via Bluetooth, 485 serial network or TCP-IP network

## PLUS



**Magnetic limit switches:** this type of limit switch ensures safe and precise installations in any ambient condition



**Control unit with programming display:** the Merak control unit with programming display with pre-programmed scenarios helps the installer in the programming phase; the control unit is arranged in an oblique way, to facilitate reading and making the settings.



**Front screws:** this arrangement of the casing screws offers ease and convenience during installation and maintenance, even when there is limited space.



**Release lever with personalised key:** the release lever simplifies motor release and the personalized key ensures its uniqueness, for better safety

• Product

• ADVANTAGES  
• PLUS

• **CONTROL UNIT**  
• **TECHNICAL FEATURES**

• ACCESSORIES

• **DISCOVER U-LINK**

## MERAK MERAK Built-In

### Incorporated control unit for one 24V operator for sliding gates



- Incorporated control unit for one 24V operator for sliding gates
- Board power supply: 230V single-phase
- Operator power supply: 24V 80W
- Main characteristics: removable terminal boards with the new colour standard, simplified programming with scenario display, integrated two-channel receiver, D-Track based antisquashing system and slowdown during opening or closing.
- Main functions: automatic closing, quick closing, pedestrian passage, people-present operation, maintenance warnings.
- Compatibility: HQSC-D, QSC-D MA

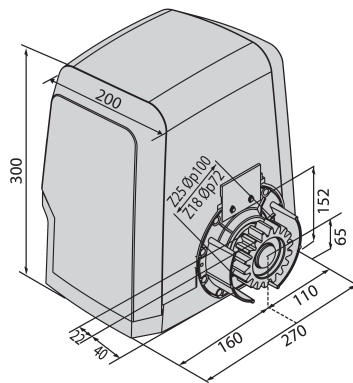

	ARES ULTRA BT A1000	ARES ULTRA BT A1500
Control unit	MERAK	
Max Leaf	1000 kg	1500 kg
Power supply	24 V	
Power input	240 W	400 W
Pinion module	4	
Slowdown	yes	
Locking	mechanical	
Release	lever-operated with personal key	
Frequency of use	intensive	
Environmental conditions	from -20 °C to 55 °C	
Protection rating	IP44	
Actuator weight	7 kg	
Impact reaction	d-track	

• Product

• ADVANTAGES  
• PLUS

• CONTROL UNIT  
• TECHNICAL FEATURES

• ACCESSORIES

• DISCOVER U-LINK

	Code	Name	Description
	D111904	<b>MITTO B RCB02 R1</b>	Transmitter with 2 channels. Range 50/100 m. Power supply 12 V with 1 battery type 23 A
	P121016	<b>RB</b>	4-channel wall-mounted radio control with rolling code
	D571053	<b>CVZ</b>	Steel rack, 4-module, cross-section 30 x 12 mm, length 1 m, screw-fitted on supports (supplied)
	N190104	<b>BIR C</b>	Rubber safety edge (H 30 mm), price per m
	N190040	<b>CSP 20</b>	Rubber shock absorber profile length 2000 mm
	P125018	<b>THEKE B PRA 01</b>	Metal protection box for ARES and ICARO series sliding operators
	D113748 00003	<b>RADIUS B LTA 24 R1</b>	Flashing light with incorporated antenna for motors with power supply 24 V.
	D113749 00003	<b>RADIUS B LTA 24 R2</b>	Flashing light without incorporated antenna for motors with power supply 24 V.
	D113783	<b>IPNOS B LTB 24 R1</b>	Flashing light with LED technology and built-in receiver antenna. New design language with smoke-grey cover. Power supply 24 V ac/dc.
	P123026	<b>B 00 R01</b>	Metal guard for B LTA
	P123025	<b>B 00 R02</b>	Wall mounting for B LTA series flashing beacons
	P111531	<b>B EBA BLUE ENTRY ANDROID 4</b>	 BLUE-TOOTH expansion card for Blue Entry system. Manages up to 4 smartphones with the Android operating system
	P111468	<b>B EBA RS 485 LINK</b>	Expansion board for connection of central units with serial controls management
	P111467	<b>B EBA WIE DRIVER</b>	Expansion card for connection of WIEGAND accessories, compatible with U-Link control units
	P903018	<b>PHP</b>	 Pair of aluminium posts for THEA/DESME series photocells Height 522 mm

· Product

· ADVANTAGES  
· PLUS

· CONTROL UNIT  
· TECHNICAL FEATURES

· ACCESSORIES

· DISCOVER U-LINK

	Code	Name		Description
	P111527	<b>DESME A15 O</b>		Pair of photocells adjustable 40 ° horizontally and 10 ° vertically. IR signal synchronised to prevent any risk of blinding. Range 30 m. Power supply 24 V ac/dc.
	P111526	<b>DESME A15</b>		Pair of self-aligning photocells. Range 30 m. Power supply 24 V ac/dc. Pair of self-aligning photocells. Range 30 m. Power supply 24 V ac/dc.
	P111528	<b>THEA A15 O.PF</b>		Pair of adjustable photocells with integrated flashing light. Possibility of directing the beam 40 ° horizontally and 10 ° vertically. IR signal synchronised to prevent any risk of blinding. Range 30 m. Power supply 24 V ac/dc. For external application.
	P121025	<b>Q.BO PAD</b>		Vandalproof outdoor digital button panel. Metal structure and s/steel buttons. Compatible with WIEGAND protocol, it ensures maximum system safety as it does not directly control gate opening. Vandalproof digital push-button panel, for outdoor use. Metal structure and s/steel buttons. Compatible with WIEGAND protocol, it ensures maximum system safety as it does not directly control the opening of the entry point.
	P121024	<b>Q.BO TOUCH</b>		Wireless digital touchpad with 433MHz rolling code operation. Manages up to 10 channels and 100 codes.
	P121022	<b>Q.BO KEY WM</b>		Key selector for outdoor use with double contact. Key selector for outdoor use with double contact.
	P121023	<b>Q.BO KEY WM AV</b>		Vandalproof key selector with double contact, for outdoor use. Metal structure. Vandalproof key selector with metal structure. Vandalproof key selector with double contact, for outdoor use. Metal structure.
	P125035	<b>SL BAT2</b>		Emergency battery kit for Deimos BT A, Ares BT A, Deimos Ultra BT A, Ares Ultra BT A.
	N999156	<b>SFI</b>		Anchor base for ARES and ICARO (supplied with operator)
	D831081	<b>CMS</b>		Sign



· Product

· ADVANTAGES  
· PLUS

· CONTROL UNIT  
· TECHNICAL FEATURES

· ACCESSORIES

· DISCOVER U-LINK

## What is U-Link?

The innovative technology that gives you new power

An exclusive Bft innovation: U-Link (Universal Link) is an exclusive Bft platform that allows the creation of technological ecosystems. In Home Automation Access, it allows communication with all the home access automation devices of any brand. So you save time and can control everything with ease, without any worries.

### It is intuitive

Easy to install and use

### It is scalable

Allows an unlimited number of devices to be added

### It is flexible

Allows the creation of groups of interconnected products

### It is practical

Works with or without a web connection

### It is functional

Parameters can be controlled remotely via dedicated applications

- Product
- ADVANTAGES  
· PLUS
- CONTROL UNIT  
· TECHNICAL FEATURES
- ACCESSORIES
- DISCOVER U-LINK

## All in one scheme: discover this amazing technology

A unique platform **allowing the creation of technological ecosystems** offering a wide range of solutions for different sectors.

Thanks to the B-Eba cards and the Clonix U-Link receiver, this proprietary platform featured by Bft products adapts to any protocol and access automation product (even BFT, non-native U-Link or non-BFT products), and is used in various sectors. Each device thus becomes smart and can be interconnected with other systems, thanks to a language that becomes universal.

### U-Base 2



Software to install and easily and comfortably carry out maintenance and identify any malfunction of U-link compatible operators.

### U-SDK



U-SDK is the innovative application that can make Bft automation systems compatible and easily integrated with a BMS network for the supervision of buildings.



### Magistro

An innovative and easy to install system for easily managing all home automation systems.



### U-Control

U-Control is the application that helps the quick and easy integration of BFT automation systems in large building management systems.



### Blue-Entry

Technology abreast of the times and attentive to daily needs: thanks to the use of U-link the house gate can now be opened with just your smartphone.



### Clonix U-Link

Allows the connection of non-native U-Link products or non-Bft products to U-Link systems.

Bft operators, non-native U-Link products or a product belonging to other brands: can they be connected to U-Link? Yes, thanks to the Clonix receivers. Accessories that know no limits.

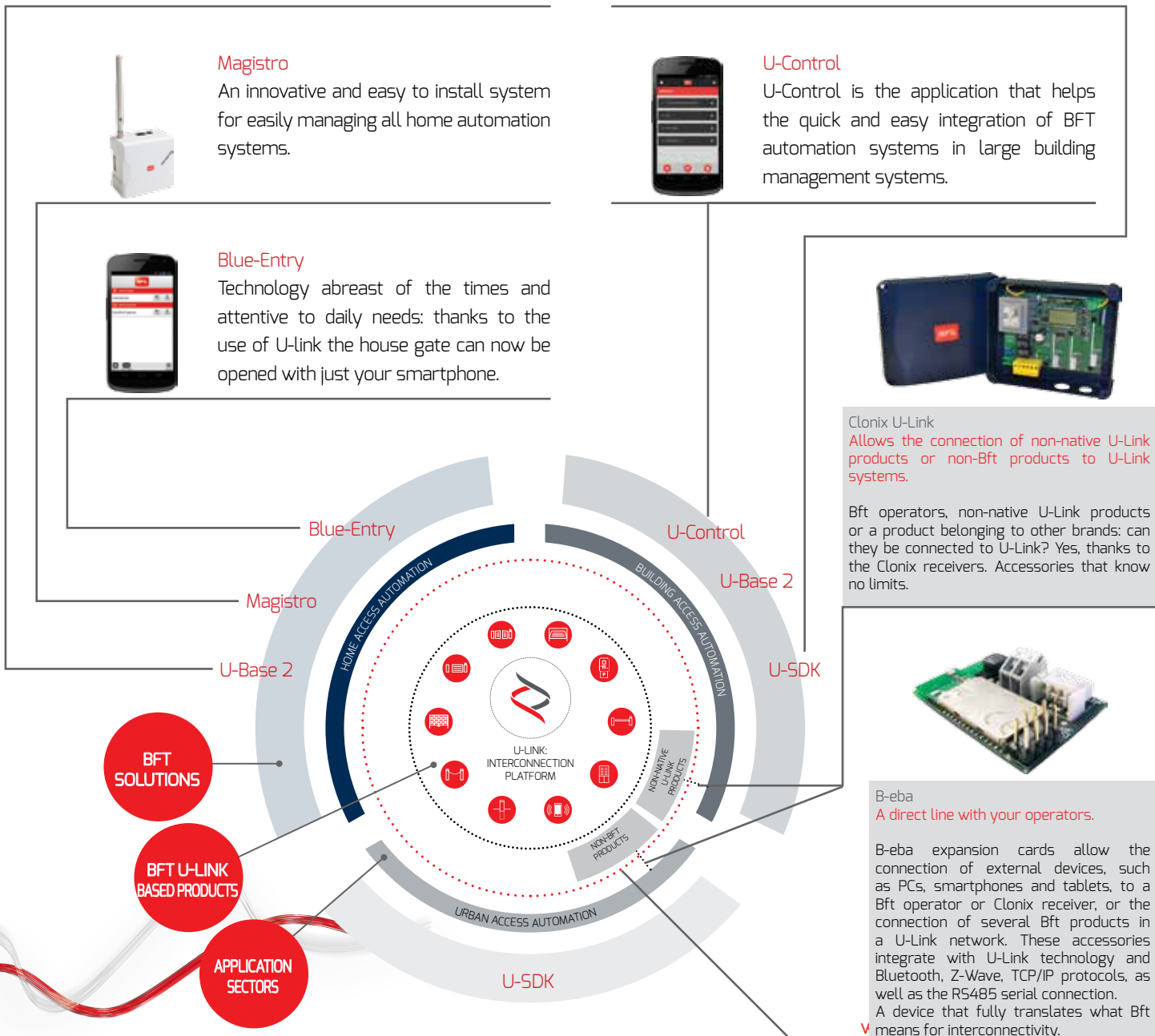

### B-Eba

A direct line with your operators.

B-Eba expansion cards allow the connection of external devices, such as PCs, smartphones and tablets, to a Bft operator or Clonix receiver, or the connection of several Bft products in a U-Link network. These accessories integrate with U-Link technology and Bluetooth, Z-Wave, TCP/IP protocols, as well as the RS485 serial connection.

A device that fully translates what Bft means for interconnectivity.





INFORMATION REGARDING THE PROTECTION OF THE INDUSTRIAL AND INTELLECTUAL PROPERTY RIGHTS OF BFT. BFT S.p.A. protects its industrial property by depositing trademarks, patents, models and designs. The intellectual property of BFT S.p.A. is protected by copyright law. BFT S.p.A. also protects its know-how by taking measures to protect the technical and commercial information inherent in its company and products. All the products in this catalogue are ORIGINAL BFT MODELS and only BFT S.p.A is authorised to produce them and market them anywhere in the world. All the commercial names in this catalogue are owned by BFT S.p.A., and only BFT S.p.A. is authorised to use them in relation to the corresponding merchandise category. FALSIFIERS WILL BE PROCEEDED AGAINST IN ACCORDANCE WITH BOTH CIVIL AND CRIMINAL LAW. THESE CONDITIONS NOT ONLY GUARANTEE THE INTELLECTUAL PROPERTY RIGHTS OF BFT, BUT ALSO PROTECT CUSTOMERS BY GUARANTEEING THAT THE PRODUCTS THEY ARE PURCHASING ARE ORIGINAL BFT PRODUCTS RESULTING FROM STUDIES AND DESIGNS WITHIN THE BFT COMPANY.